

# PRODUCT INFORMATION PACKET

Model No: 213TTFBD6028

Catalog No: GT1216A

7.50 HP General Purpose Motor, 3 phase, 1800 RPM, 230/460 V, 213TC Frame, TEFC  
Three Phase TEFC Motors





### Nameplate Specifications

Output HP	<b>7.50 Hp</b>	Output KW	<b>5.6 kW</b>
Frequency	<b>60 Hz</b>	Voltage	<b>230/460 V</b>
Current	<b>19.0/9.5 A</b>	Speed	<b>1768 rpm</b>
Service Factor	<b>1.15</b>	Phase	<b>3</b>
Efficiency	<b>91.7 %</b>	Power Factor	<b>79.3</b>
Duty	<b>Continuous</b>	Insulation Class	<b>F</b>
Design Code	<b>B</b>	KVA Code	<b>H</b>
Frame	<b>213TC</b>	Enclosure	<b>Totally Enclosed Fan Cooled</b>
Thermal Protection	<b>No</b>	Ambient Temperature	<b>40 °C</b>
Drive End Bearing Size	<b>6307</b>	Opp Drive End Bearing Size	<b>6206</b>
UL	<b>Listed</b>	CSA	<b>Y</b>
CE	<b>Y</b>	IP Code	<b>43</b>
Hazardous Location	<b>DIVISION 2 T2B</b>		

### Technical Specifications

Electrical Type	<b>Squirrel Cage Inverter Rated</b>	Starting Method	<b>Line Or Inverter</b>
Poles	<b>4</b>	Rotation	<b>Reversible</b>
Resistance Main	<b>1.473 Ohms</b>	Mounting	<b>Rigid Base</b>
Motor Orientation	<b>Horizontal</b>	Drive End Bearing	<b>Ball</b>
Opp Drive End Bearing	<b>Ball</b>	Frame Material	<b>Rolled Steel</b>
Shaft Type	<b>T</b>	Overall Length	<b>19.10 in</b>
Frame Length	<b>9.65 in</b>	Shaft Diameter	<b>1.375 in</b>
Shaft Extension	<b>3.38 in</b>	Assembly/Box Mounting	<b>F1/F2 CAPABLE</b>
Connection Drawing	<b>EE7308</b>	Outline Drawing	<b>SS620688-100</b>

# Uncontrolled Copy

SS620688

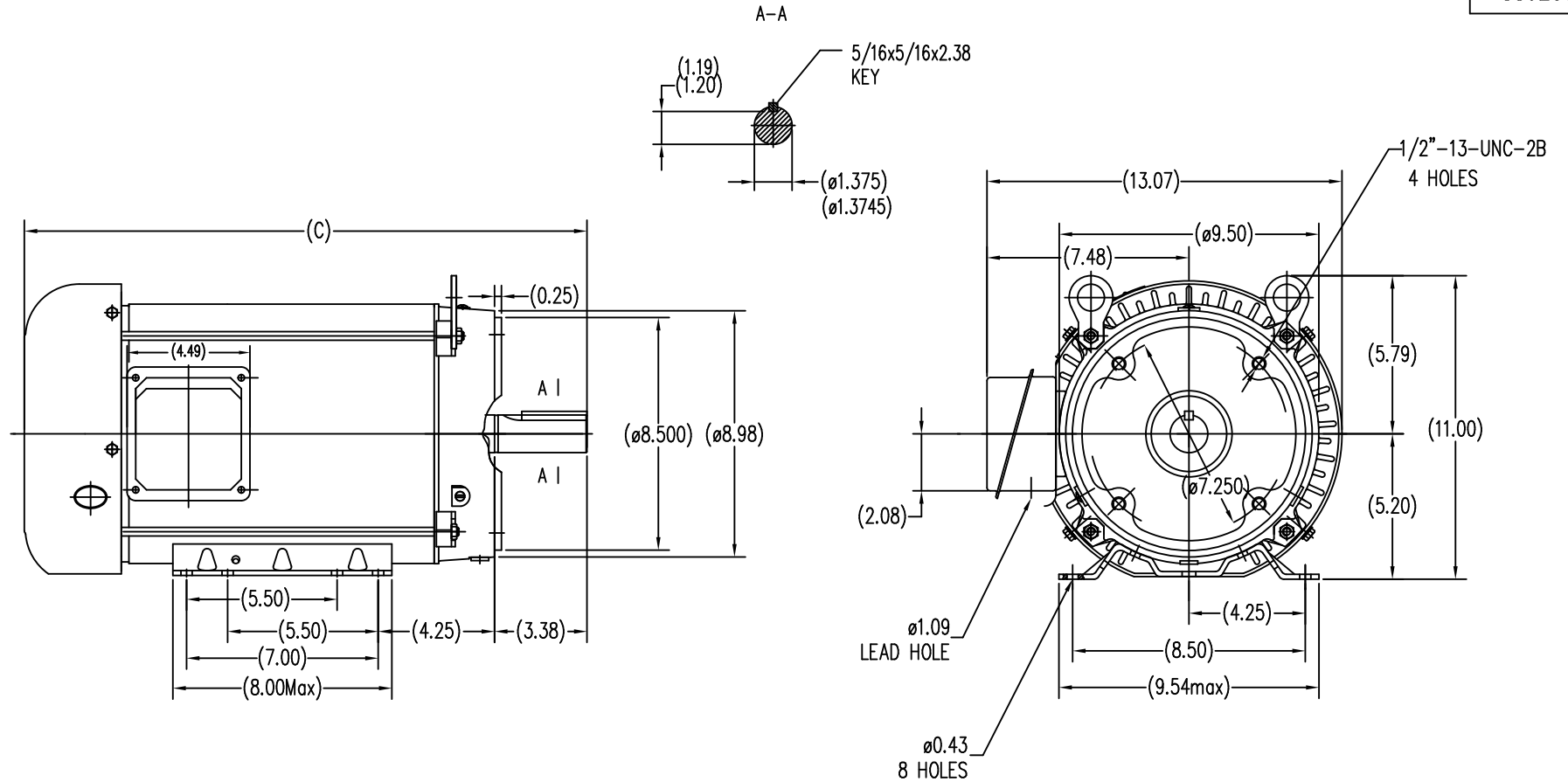

213TC	19.1
215TC	20.7
FRAME	C

		TOLERANCES UNLESS SPECIFIED		REGAL REGAL-BELOIT CORPORATION		DRAWN ZXW 06-03-2015	
		DEC.	INCHES			CHK ZL 06-03-2015	
		.X	±.1			APPD ZYH 06-03-2015	
		.XX	±.03	TITLE		SCALE	
		.XXX	±.005	213/215TC-Face		REF	
		.XXXX	±.0005	MAT'L		FMF REGAL-WUXI	
NO.	REVISION	BY & DATE	CHK	ANG	±1/2"	FINISH	PREV
THIS DRAWING IN DESIGN AND DETAIL IS OUR PROPERTY AND MUST NOT BE USED EXCEPT IN CONNECTION WITH OUR WORK ALL RIGHTS OF DESIGN AND INVENTION ARE RESERVED THIS IS AN ELECTRONICALLY GENERATED DOCUMENT - DO NOT SCALE THIS PRINT				RFP	CAD FILE	SS620688	SIZE
				DIST			DRAWING NO.
							B
							SS620688
							REV.
							2



NO.	REVISION	BY & DATE	CHK	ANG	TOLERANCES UNLESS SPECIFIED		FINISH	DRAWN RM 11/20/1990				
					DEC.	INCHES						
5	CHG TO REGAL LOGO	SL 09/10/2015	AB					CHK ML 11/21/1990				
4	REVISED IEC NOTATIONS	MSG 11/15/2011	CMN	.X	±.1			APPD SAS 04/24/2003				
3	ADDED IEC NOTATIONS... (U1), (V1) ETC. MU95194	MSG 5/10/2010	MJS	.XX	±.02		TITLE CONNECTION DIAGRAM	SCALE 1=1				
2	ADDED THE OPTIONAL CORD CONNECTION MU46318	RDH 04/24/2003	DRS	.XXX	±.005		3Ø - DUAL VOLTAGE MOTOR	REF				
1	REDRAWN	RM 11/20/1990		.XXXX	±.0005		MAT'L.	FMF				
					±7'30"			PREV				
THIS DRAWING IN DESIGN AND DETAIL IS OUR PROPERTY AND MUST NOT BE USED EXCEPT IN CONNECTION WITH OUR WORK ALL RIGHTS OF DESIGN AND INVENTION ARE RESERVED THIS IS AN ELECTRONICALLY GENERATED DOCUMENT - DO NOT SCALE THIS PRINT							RFP	CAD FILE ee7308	SIZE A	DRAWING NO. EE7308	PAGE OF 5	REV. 5
							DIST WP					



**P.O. BOX 8003  
WAUSAU, WI 54401-8003  
PH. 715-675-3311**

**CERTIFICATION DATA SHEET**

**CUSTOMER:** CUSTOMER PO #:  
**ORDER #:** MODEL #: 213TTFBD6028 AA  
**CONN. DIAGRAM:** A-EE7308 CUSTOMER PART #:  
**OUTLINE:** B-SS620688 MOUNTING: F1/F2 CAPABLE  
**WINDING #:** HE31324012 2

**TYPICAL MOTOR PERFORMANCE DATA**

HP	KW	SYNC. RPM	F.L. RPM	FRAME	ENCLOSURE	KVA CODE	DESIGN	
7 1/285	5.6083.70	1800	1768&1475	213TC	TEFC	H	B	
PH	Hz	VOLTS	AMPS	START TYPE	DUTY	INSL	S.F.	AMB°C
3	60/50	230/460&190/380	19/9.5&16/8	LINE OR INVERTER	CONTINUOUS	F7	1.15/1.0	40

<b>FULL LOAD EFF:</b>	91.7&91	<b>3/4 LOAD EFF:</b>	93	<b>1/2 LOAD EFF:</b>	90	<b>GTD. EFF</b>	91	<b>ELEC. TYPE</b>
<b>FULL LOAD PF:</b>	80&76.5	<b>3/4 LOAD PF:</b>	73.4	<b>1/2 LOAD PF:</b>	63.8	<b>SQ CAGE INV RATED</b>		

F.L. TORQUE LB-FT	LOCKED ROTOR AMPS	L.R. TORQUE LB-FT	202 %	B.D. TORQUE LB-FT	265 %	F.L. RISE°C
22.3	124 / 62	45		59		40

SOUND PRESSURE @ 3 FT. DBA	SOUND POWER DBA	ROTOR WK^2 LB-FT^2	75 LB-FT^2	SAFE STALL TIME SEC.	25 SEC.	STARTS / HOUR	2	APPROX. MOTOR WGT LBS.	175
62	72	0.95							

**\*\*\* SUPPLEMENTAL INFORMATION \*\*\***

DE BRACKET TYPE	ODE BRACKET TYPE	MOUNT TYPE	ORIENTATION	SEVERE DUTY	HAZARDOUS LOCATION	DRIP COVER	SCREENS	PAINT
C-FACE	STANDARD	RIGID	HORIZONTAL	FALSE	NONE	FALSE	NONE	BLUE (ENAMEL)

BEARINGS DE ODE	GREASE	SHAFT TYPE	SPECIAL DE	SPECIAL ODE	SHAFT MATERIAL	FRAME MATERIAL
BALL BALL 6307 6206	POLYREX EM	T	NONE	NONE	1045 HOT ROLLED (C-204)	ROLLED STEEL

THERMO-PROTECTORS				THERMISTORS		
THERMOSTATS	PROTECTORS	WDG RTDS	BRG RTDS	CONTROL	SPACE HEATERS	VOLTS
NONE	NOT	NONE	NONE	NONE	FALSE	NONE

<b>* INVERTER TORQUE:</b>	CONSTANT 10:1
<b>INV. HP SPEED RANGE:</b>	NONE
<b>ENCODER:</b>	NONE
<b>O NONE</b>	NONE
<b>T NONE</b>	PPR
<b>E NONE</b>	P/N NONE
<b>S NONE</b>	NONE
<b>* FT-LB</b>	NONE V NONE HZ

**PREPARED BY:** Fareeda Dudekula  
**DATE:** 05/14/2018 01:14:29 AM  
**FORM 3531 REV.3 02/07/99**  
**\*\* Subject to change without notice.**

Data Sheet

Date: 5/3/2018

2131TFBD6028

Customer: \_\_\_\_\_  
 Attention: \_\_\_\_\_



Submital

Submitted by: FAREEDA DUDEKULA

Data @ 460 V

Motor Load Data

Load	0%	25%	50%	75%	100%	115%	125%	LR
Current (Amps)	4.6	5.0	6.1	7.7	9.5	10.8	11.6	62.0
Torque (ft-lb)	0.00	5.5	11.0	16.6	22.3	25.6	28.0	45.0
RPM	1800	1792	1785	1775	1768	1,762	1758	0
Efficiency (%)		85.5	90.2	91.7	91.7	91.4	91.0	
P.F. (%)	6.0	41.0	63.0	74.5	80.0	82.0	83.0	43.0

Motor Speed Data

	LR	Pull-Up	BD	Rated	Idle
Speed (RPM)	0	900	1580	1768	1800
Current (Amps)	62.0	56.0	35.0	9.5	4.6
Torque (ft-lb)	45.0	38.0	59.0	22.3	0.00

Information Block

HP	7.5			
Sync. RPM	1800			
Frame	213182TFC6080			
Enclosure	TEFC			
Construction	TFC			
Voltage	230/460#190/380 V			
Frequency	60 Hz			
Design	B			
LR Code letter	H			
Service Factor	1.15			
Temp Rise @ FL	40 °C			
Duty	CONT			
Ambient	40 °C			
Elevation	1,000 feet			
Rotor/Shaft wk²	0.95 Lb-Ft²			
Ref Wdg	HE31324012 NONE			
Sound Pressure @ 1M	62 dbA			
VFD Rating	CONSTANT 10:1			
Outline Dwg	B-SS620688			
Conn. Diag	A-EE7308			
Additional Specifications:				
0				
0				
R1	R2	X1	X2	Xm
0.9110	0.5480	2.6610	3.0810	56.8890
EQUIV/CKT (OHMS/PHASE)				

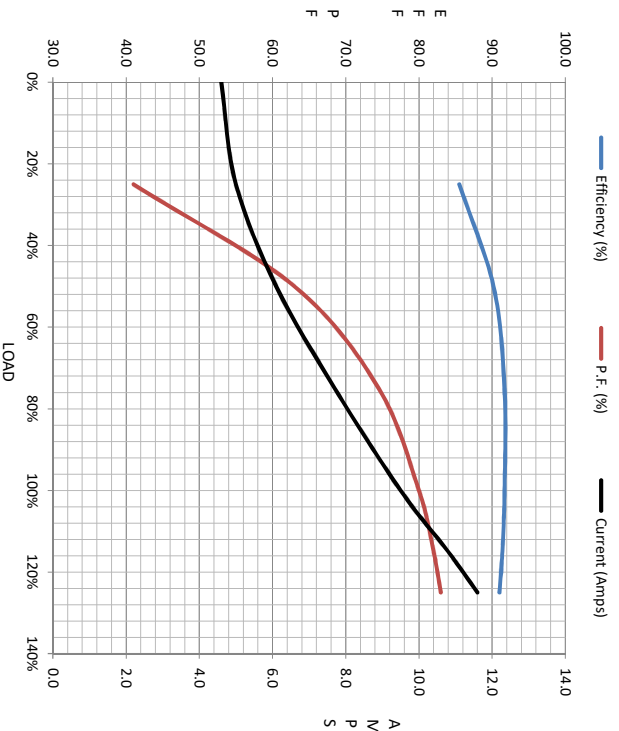

Speed - Torque Curve

